

How to spot faulty shock absorbers.

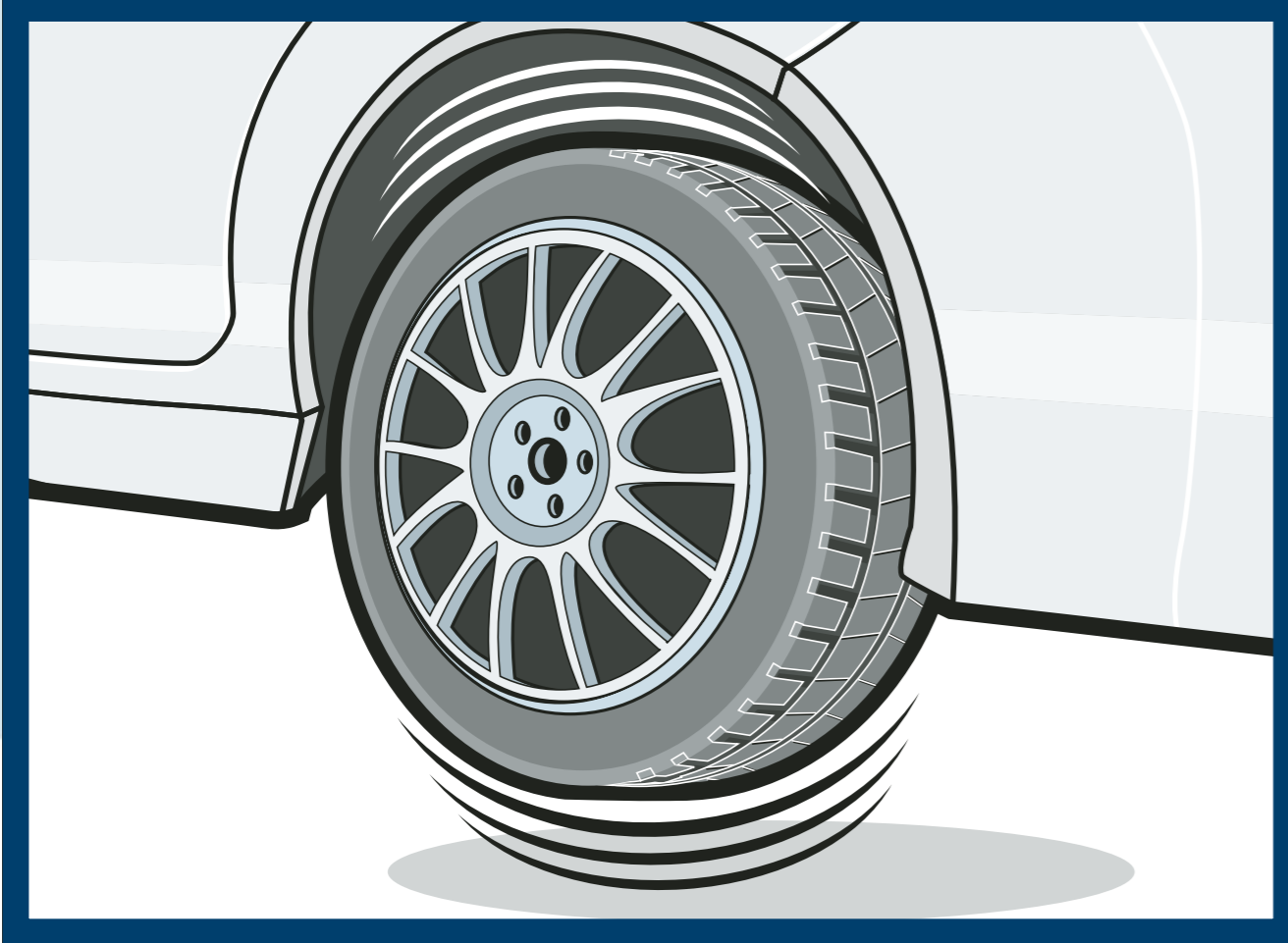

Wheels bounce

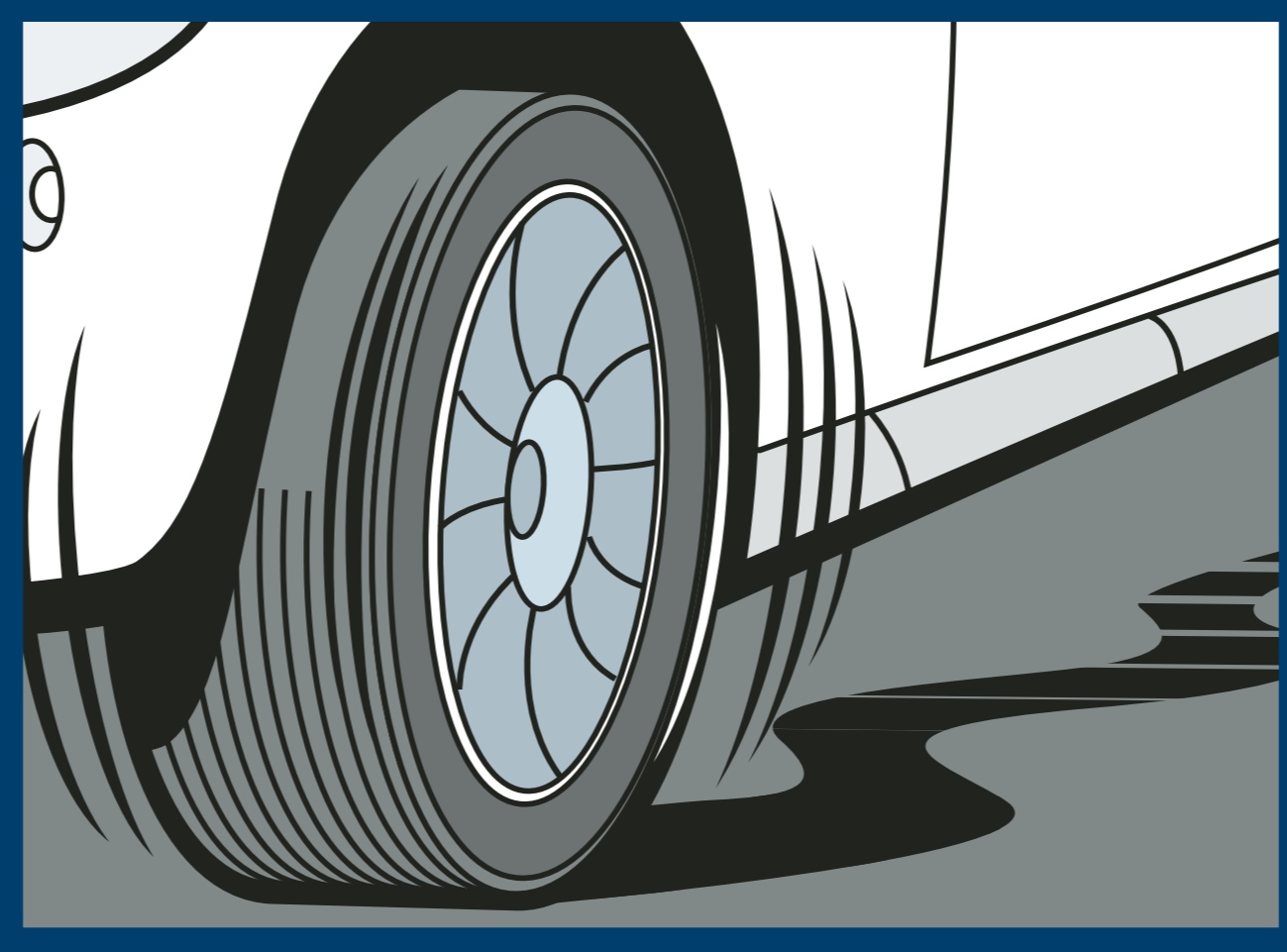

Steering vibrates

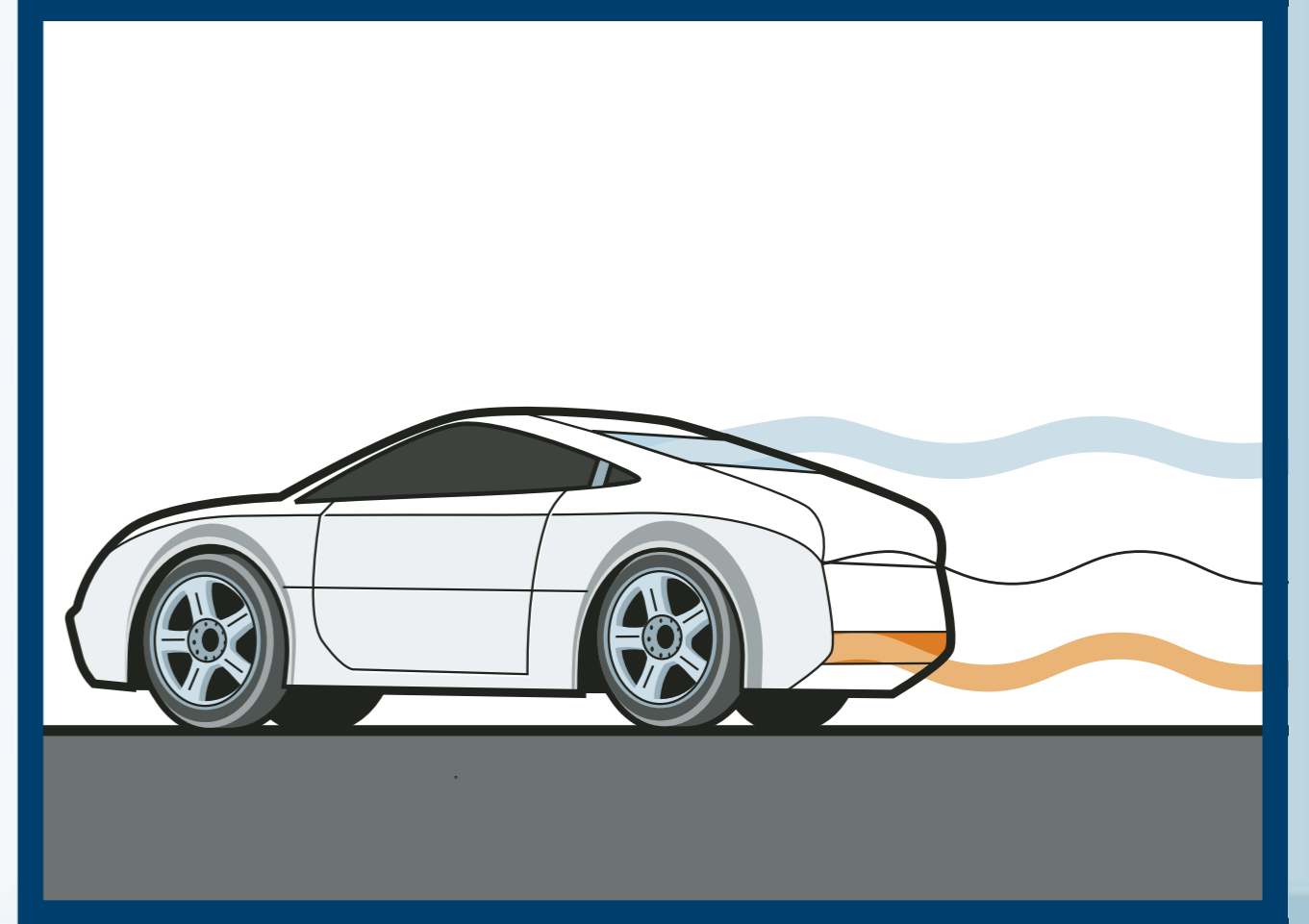

Car body sways

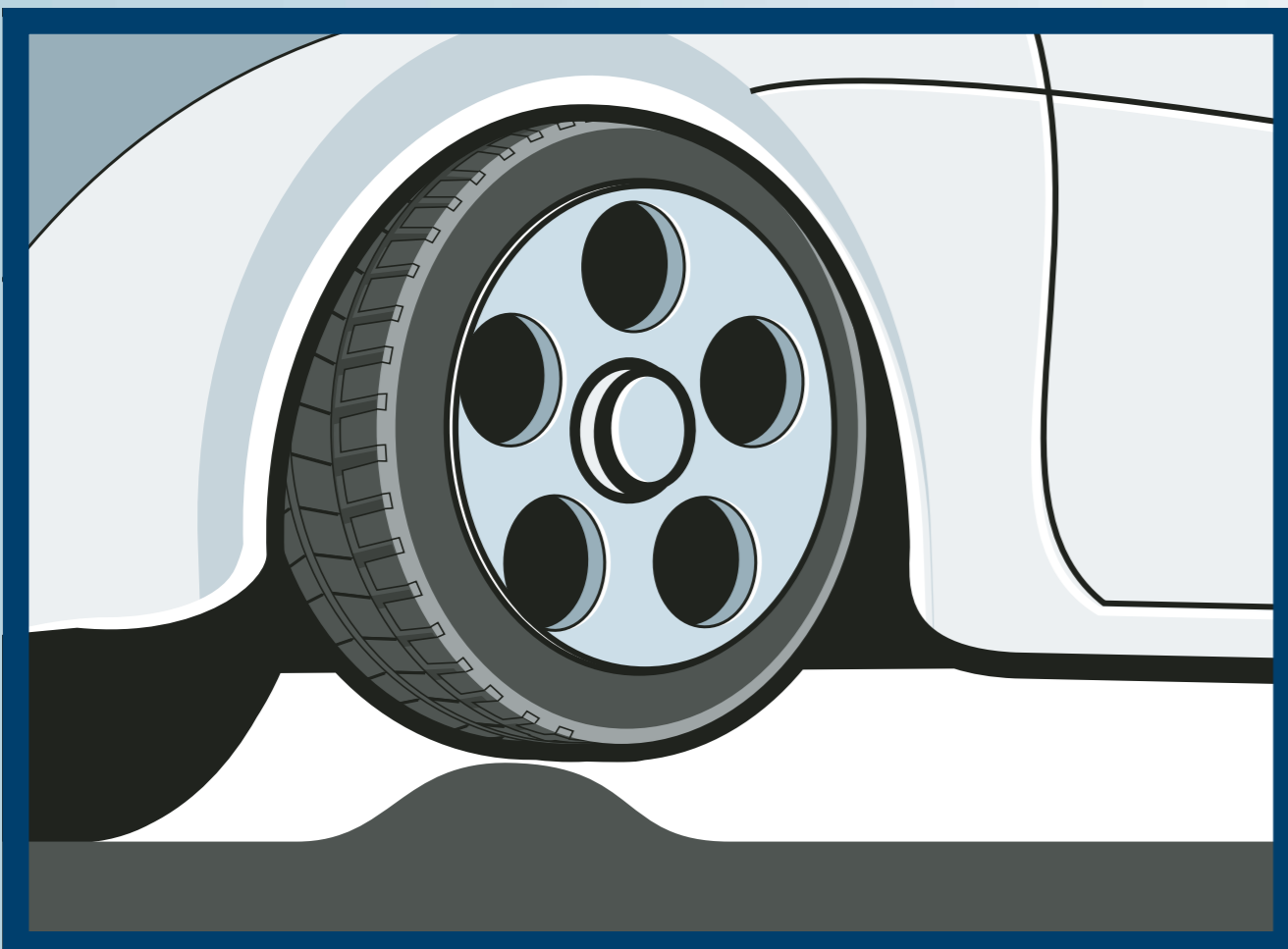

Suspension bottoms out

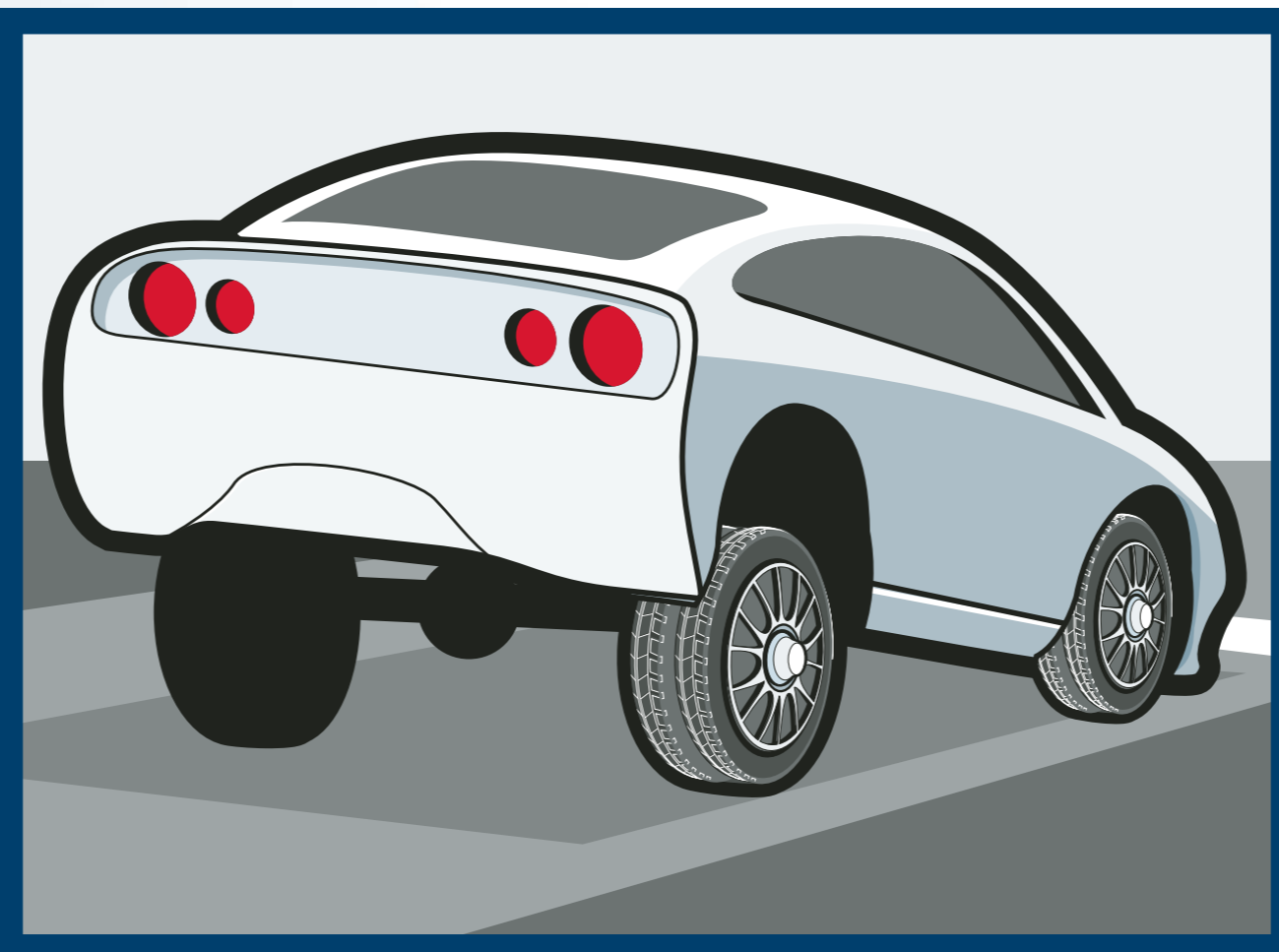

Car 'dives' during braking

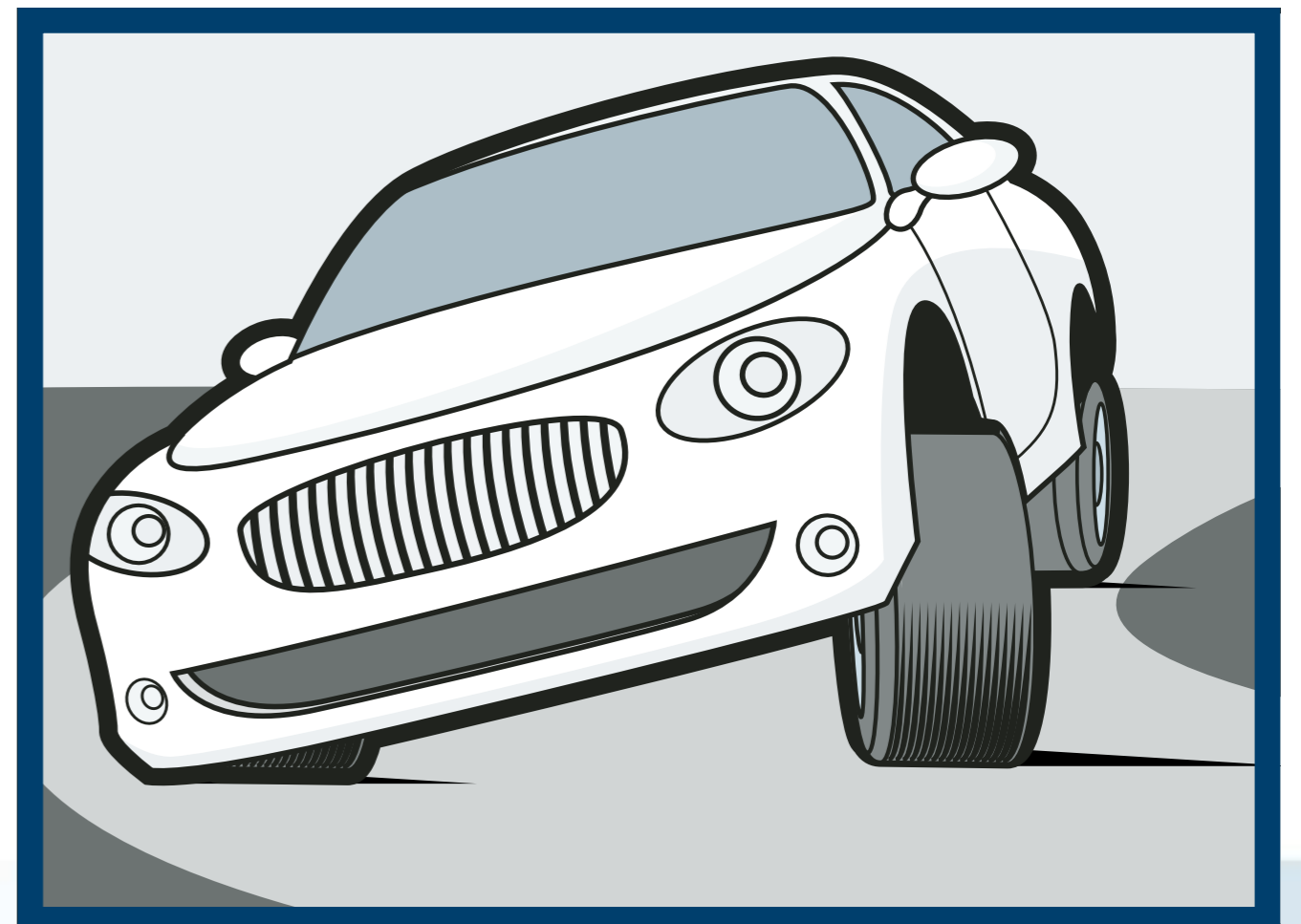

Poor cornering stability

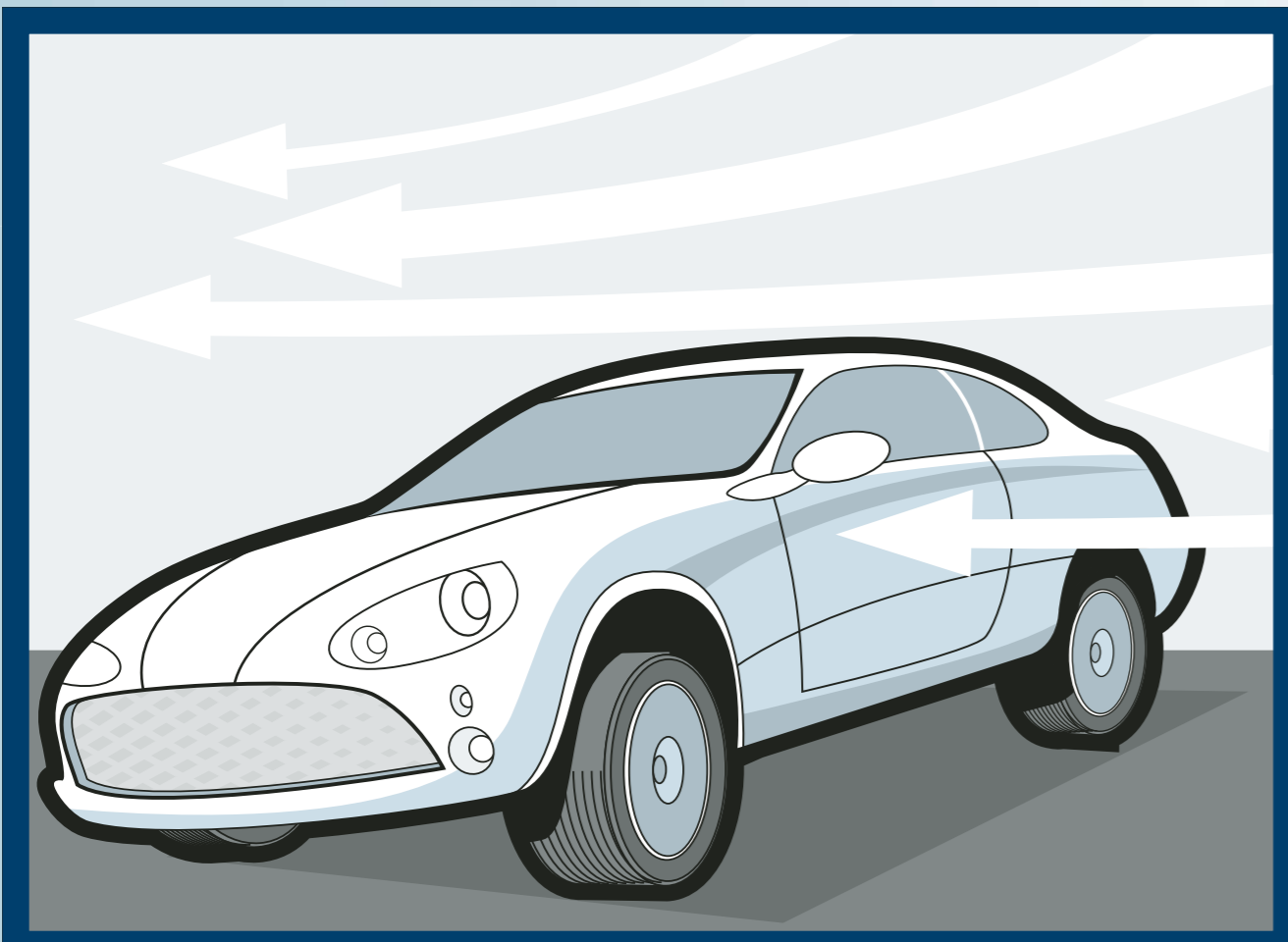

High susceptibility to side winds



Oil on the shock absorber
(a fine film of oil is needed for self-lubrication of the piston rod)

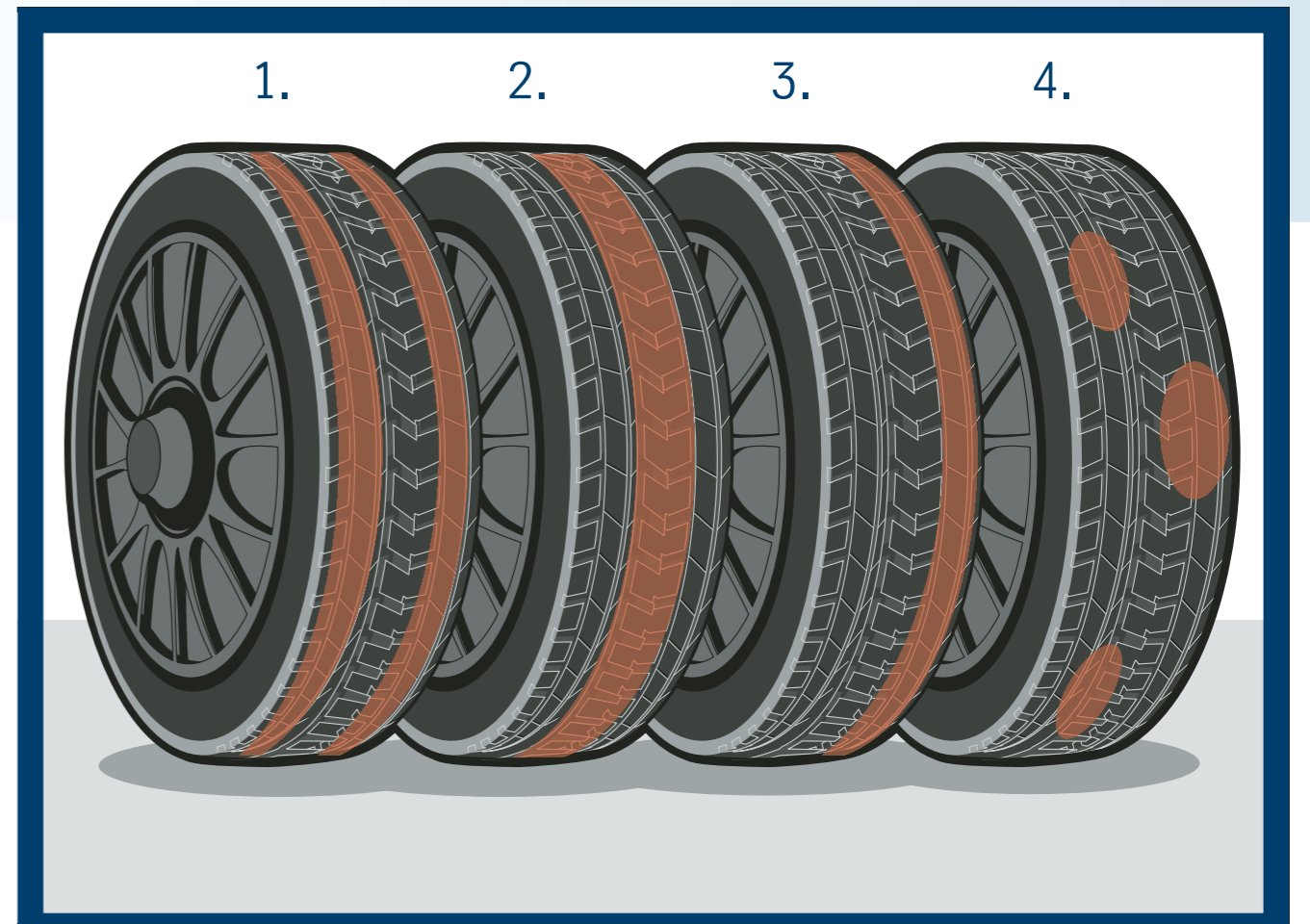

Uneven tyre wear
1. Tyre pressure too low
2. Tyre pressure too high
3. Faulty suspension or steering geometry
4. Wheel imbalance or faulty shock absorbers

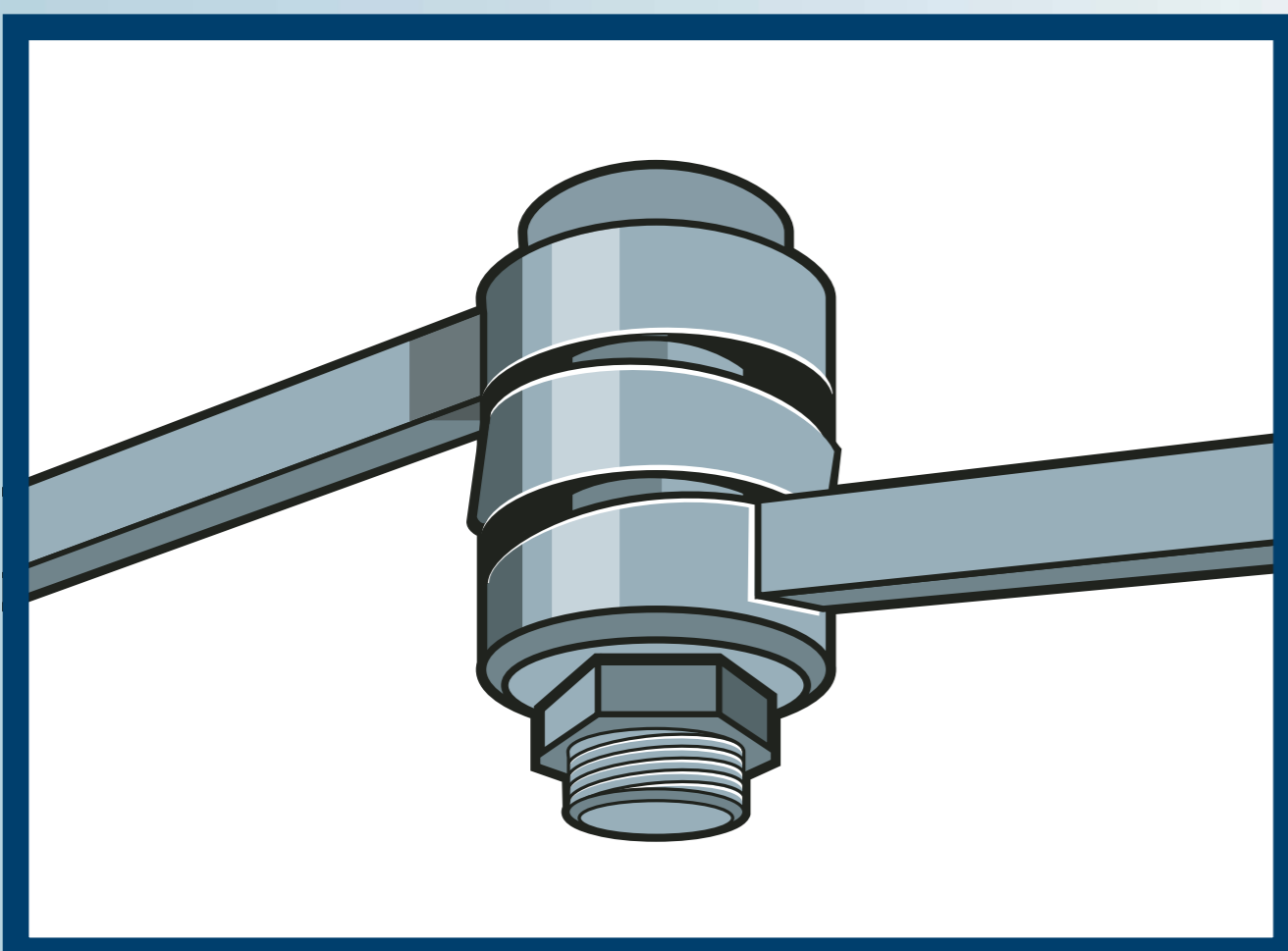

Worn-out ball joints

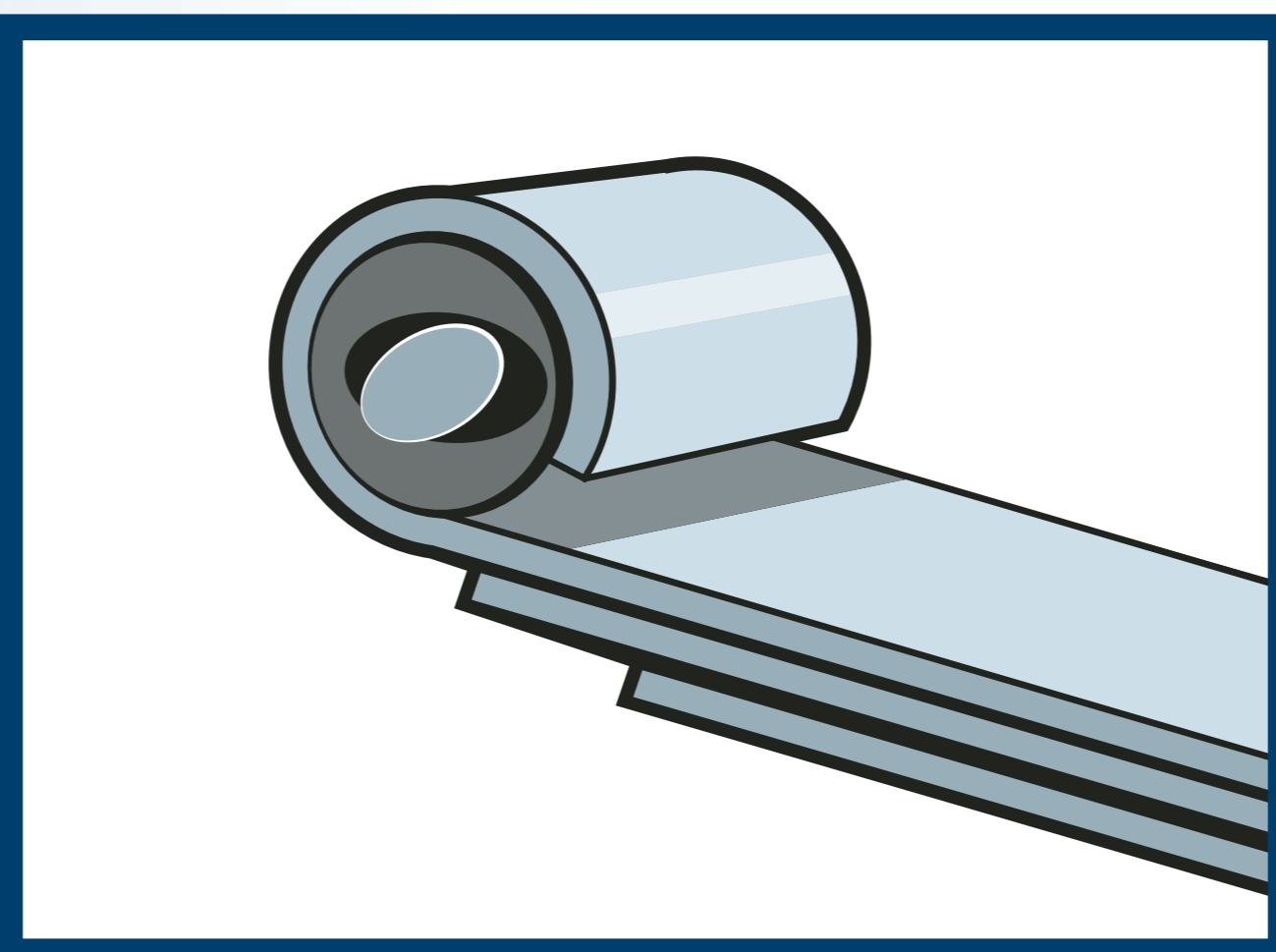

Worn-out rubber-metal attachments

www.bilstein.de • 02333 791-4444

